

**MICROSCALE DECAL NUMBER 87-599
SANTA FE FP-45 LOCOS. PASS. PAINT SCHEME
RED & SILVER**

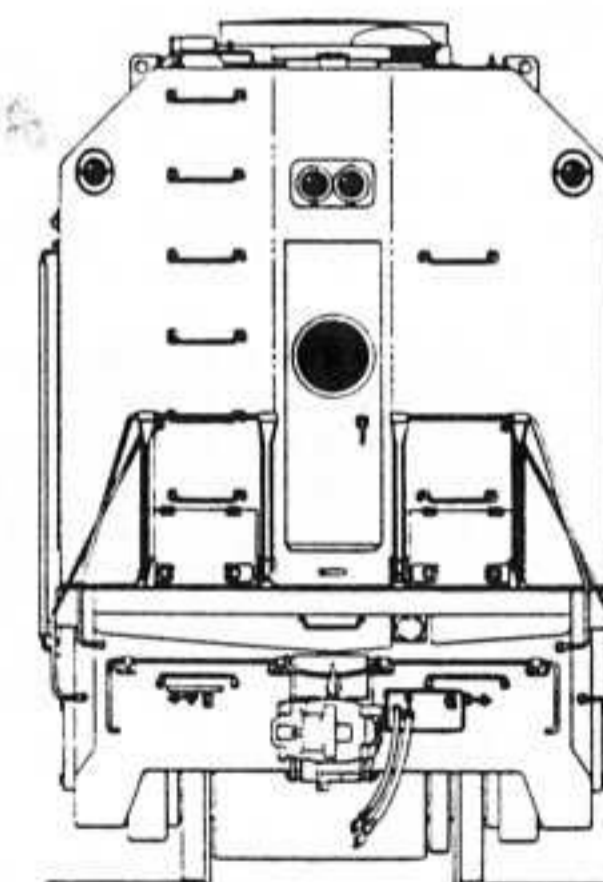
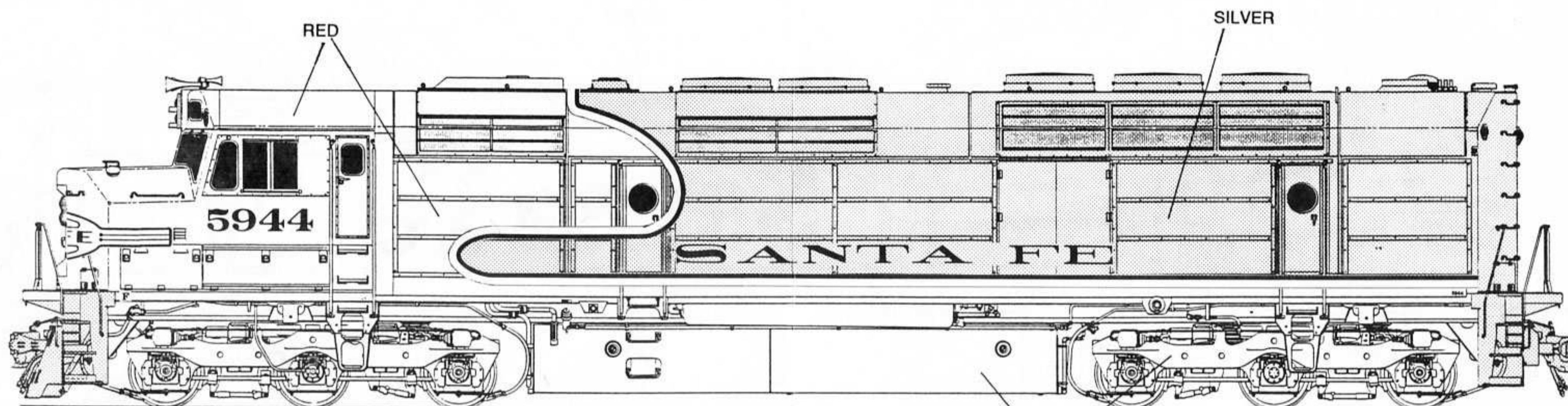

COLORS: RED - SCALECOAT SANTA FE RED
SILVER - SCALECOAT SILVER

ORIGINAL SCHEME

- HANDRAILS ON SIDE DOORS ARE SILVER
- HANDRAILS AND STANTIONS ON ENDS ARE YELLOW
- ALL GRAB IRONS MATCH BACKGROUND COLOR
- ANTICLIMBERS ARE RED
- TOP HEADLIGHT CASTING AND HEADLIGHT CASTING IN NOSE DOOR ARE YELLOW

SUPERFLEET SCHEME

- HANDRAILS ON SIDE DOORS ARE SILVER
- HANDRAILS AND STANTIONS ON ENDS, ALSO ENDS OF COUPLER LIFT BARS ARE YELLOW
- GRAB IRONS ON ENDS, NOSE, STEPS IN RED AREA LEADING TO CAB ARE BLACK
- NOSE DOOR CASTING IS YELLOW (THERE IS NO TOP HEADLIGHT)

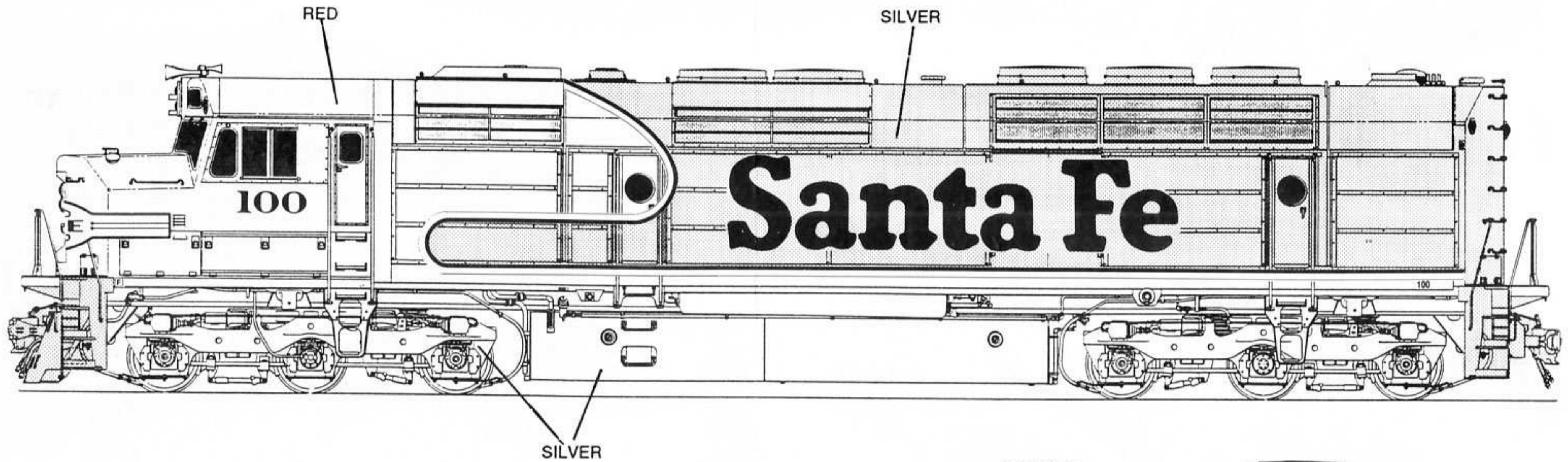

- 100-108 ORIGINAL NUMBERS WHEN DELIVERED
- 5940-5948 RENUMBERED IN 1970
- 100-107 RENUMBERED IN 1989-1990 WHEN REPAINTED FOR SUPERFLEET SERVICE
- 5990 SOME UNITS RENUMBERED TO 5900 SERIES JUST BEFORE GP-60Ms WERE DELIVERED
- 5997 WAS ONE UNIT KNOWN TO BE SO NUMBERED
- 90-98 RENUMBERED TO 90 SERIES WHEN GP-60M's WERE DELIVERED

RESEARCH COORDINATED BY DALE MARTIN

